

All Information, Schematics, Drawings & Procedures  
in this E-book are for Your Personal Use Only  
Your Purchase entitles you to build One (1) Device

Inventor & Author Reserves All Rights to  
Commercial Production

# Build Your Own Free Energy Generator



By

**J.G. Homesworth**

**Copyright © 2019**

**ISBN: 978-0-578-62721-2**

# Introduction

**After many years of Research and Study I've designed my own Free Energy Generator. The device outlined in the following pages will run continuously, powering itself and generate extra power.**

**This e-book contains plans which if followed carefully will allow almost anyone to construct their very own Fuel-less Self-Powered, Free Energy Generator.**

# Disclaimer

**With that said you need to understand that the Plans in this Book are provided for informational purposes only. The Author, Publisher and Distributor are not liable for any Injury, Loss or Damages incurred if you decide to build the Device described within these pages and to use it for any purpose. The Sole Responsibility of all or any Liability rests with you the Builder. With the purchase of this manual You are allowed to build one device for personal use.**

**The Author retains all Commercial Production Rights to the device.**

# Table of Contents

**Introduction**

**Disclaimer**

**Section 1.....Parts and Pieces**

**Section 2.....Electronic Drive Circuit**

**Section 3.....Putting it all Together**

**Section 4.....Wire Connections**

**Section 5.....Making it Bigger**

**Section 6.....Builder's Resources**

# Section 1

## Parts and Pieces

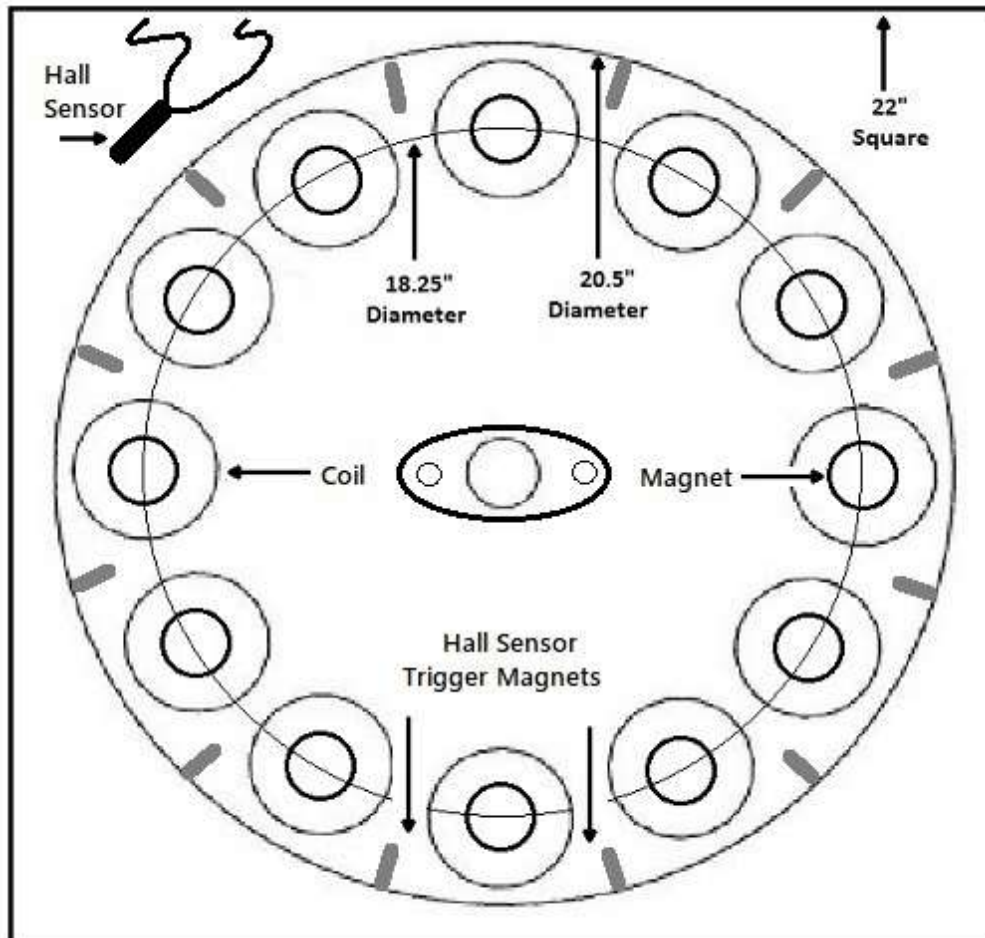

**You need 3 pieces of 3/4" plywood 22" square. find center and mark a 18.25" circle on both and one 20.5" plywood Disk the same thickness as your magnets.**

All Information, Schematics, Drawings & Procedures in this E-book are for Your Personal Use Only Your Purchase entitles you to build One (1) Device  
Inventor & Author Reserves All Rights to Commercial Production

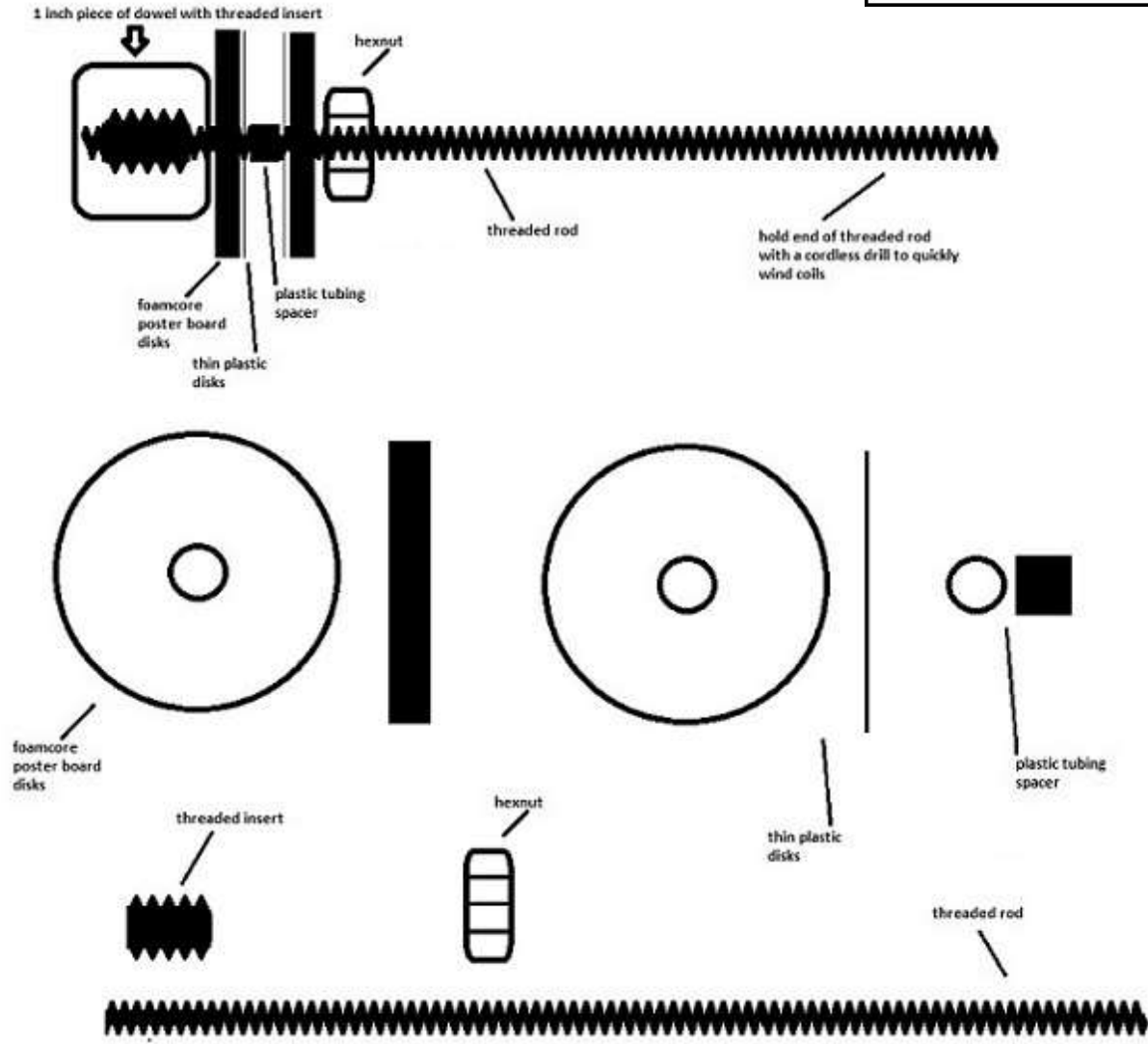

**You'll need to make a simple coil winder like the one depicted above. Clamping the threaded rod in a cordless drill chuck makes it easy to wind coils quickly.**



**You'll also need a Pull Starter from a small gas engine. Salvage one from an old mower or chainsaw. 2 Flange**

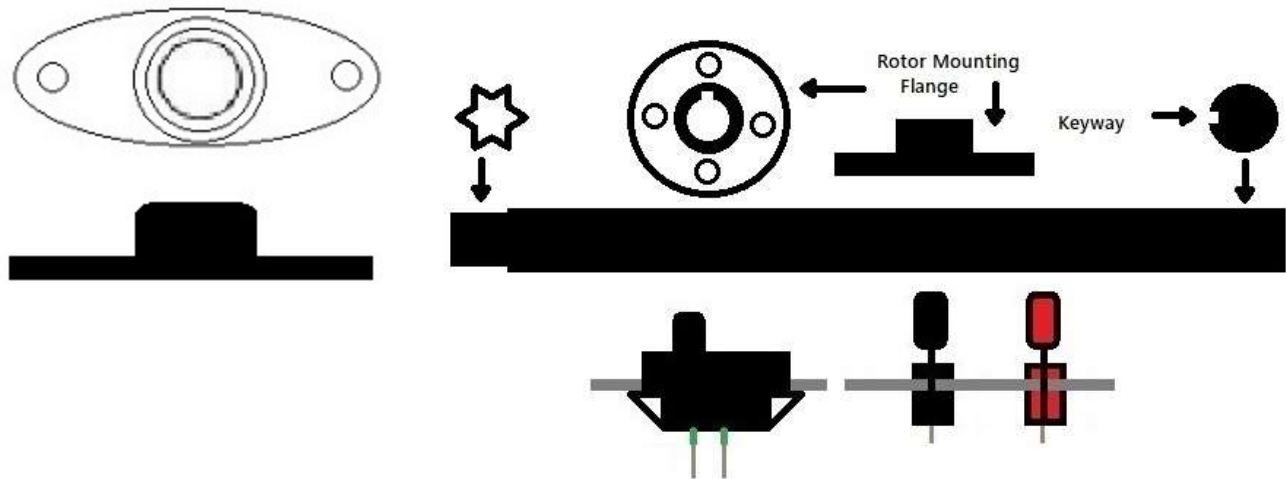

**Bearings, 2 Mounting Flanges for the Rotor to be attached to a Shaft with one end machined to match the Pull Starter Socket.**

**1 SPST switch and 2 Binding Posts**

**The only other parts besides the electronic components, magnets and enamel coated wire you'll need are some 1/4" and 1/2" plywood, wood screws and glue to build a case to enclose everything in.**

**Anybody that has some basic skills in woodworking, handyman skills fixing things around their house can build one of these Generators. You don't need to be a genius or have a Specialized Degree in order to build one.**

**What you do need is determination to start this project and see it through to the finish. You'll be glad you did and can show your friends the neat Fuelless Free Energy Generator you built.**



## Section 2

# Electronic Drive Circuit

**The drive circuit consists of 1 Hall Effect Switch, 1 Regulated Power Supply and Power Recovery Circuits for each coil**

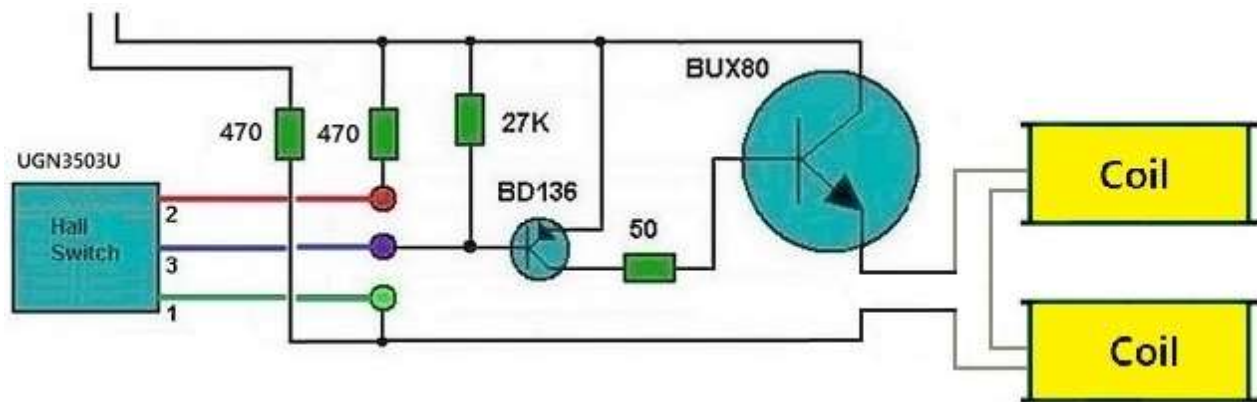

**The Hall Switch is best described as a magnetic lock. A magnetic field coming close to it is the key that opens the lock allowing current to flow. Embed small round bar magnets in the rim of the rotor and mount the hall sensor close to the rotor's rim.**

**As each magnet on the rotor passes the Hall Sensor it turns on allowing current to flow in the circuit creating a pulse that's fed into coils above and below the rotor making the rotor spin as the magnet is pushed away from the coils.**

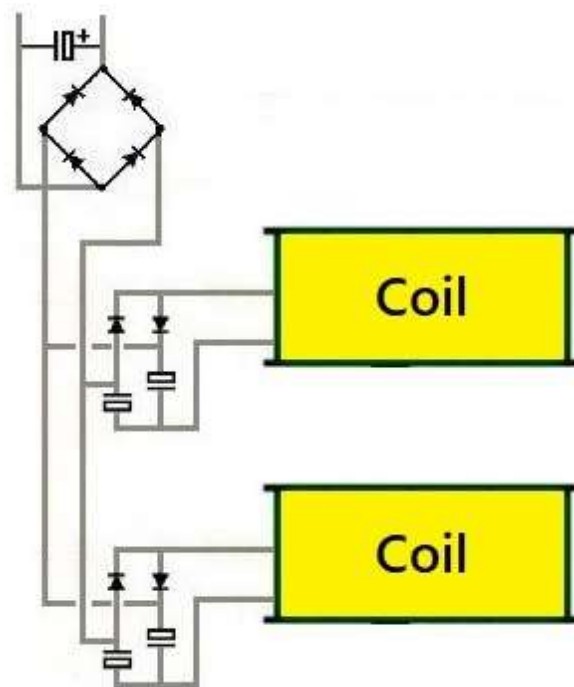

**The Power Recovery Circuit allows energy to be collected from the rising and falling magnetic field of the remaining coils on the rotor.**

**The Regulated Power Supply collects power from two coils on the Rotor to power the Hall Switch Circuit.**

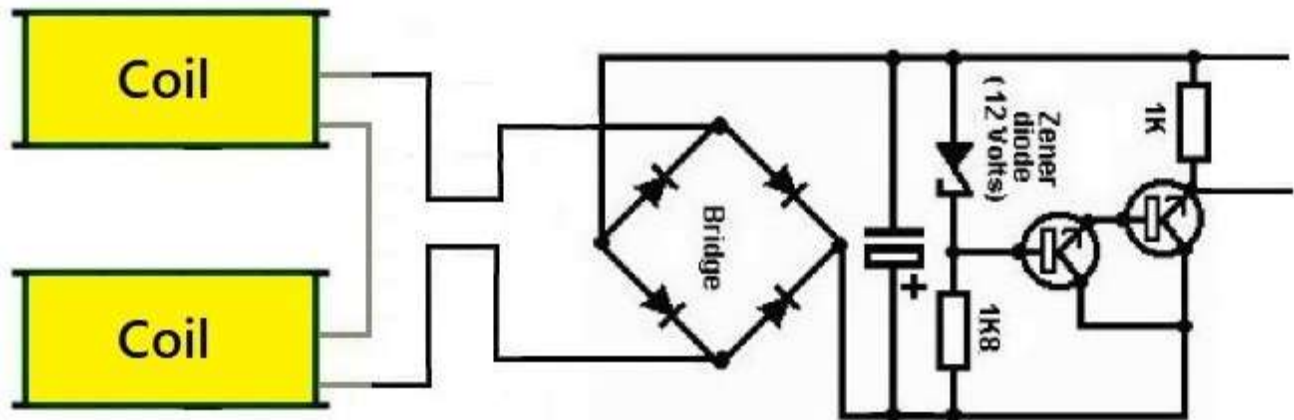

**I've kept the explanation simple so everyone reading this manual will understand how it all works without needing a Degree in Electronics, Mechanical Engineering or Physics to build one for themselves. If you do decide to build your own device, you are doing it at your own risk and that you assume all responsibility for your actions.**

# Section 3

## Putting it all Together

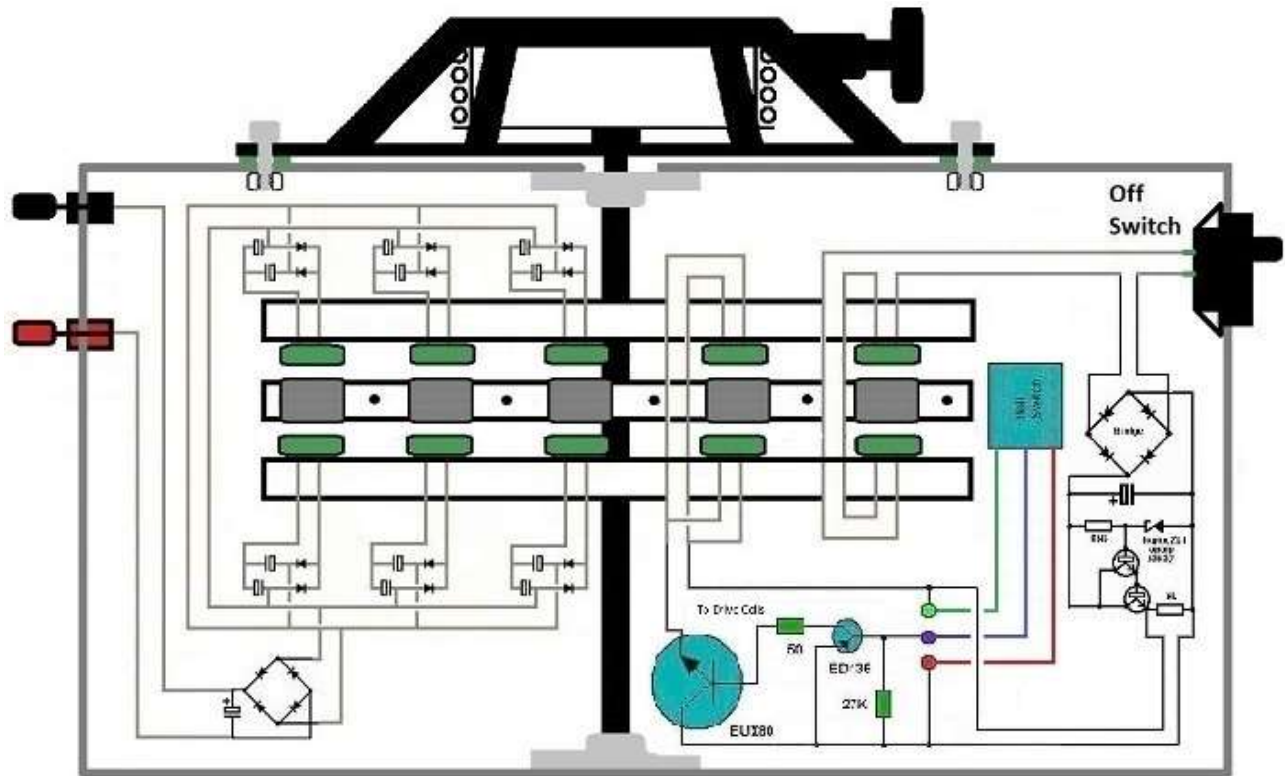

**Here's a cutaway view of the device showing how the mechanical and electronic parts are hooked up and work together.**

**The electronic components are wired up on circuit boards and protected inside plastic project boxes.**

**Wiring should be neatly bound up with wire ties and secured on the inside walls of the case so they won't rub against the Rotor or it's Shaft.**

**The last thing you want is the wires getting tangled up in the moving parts ruining your hard work.**

## **Step #1**

**Start by cutting 2 pieces of 3/4" plywood exactly 22" inches square. By stacking and cutting the 2 pieces at the same time will ensure the are**

**the same size. This is important because these pieces will be attached to the inside of the enclosure and have the coils attached to them.**

**Next take one of these 22 inch square pieces and mark lines between the corners diagonally opposite each other, where they cross is the center point from where all measurements are taken and lines are drawn.**

## **Step # 2**

**Scribe a 18.25" diameter circle and make a mark every 1.5/8" along this circle. You should have 12 evenly spaced marks. Next place a flange bearing over the x in the center of**

**the square and mark each bolt hole.**  
**This is what it should look like after**  
**you finished making those marks.**

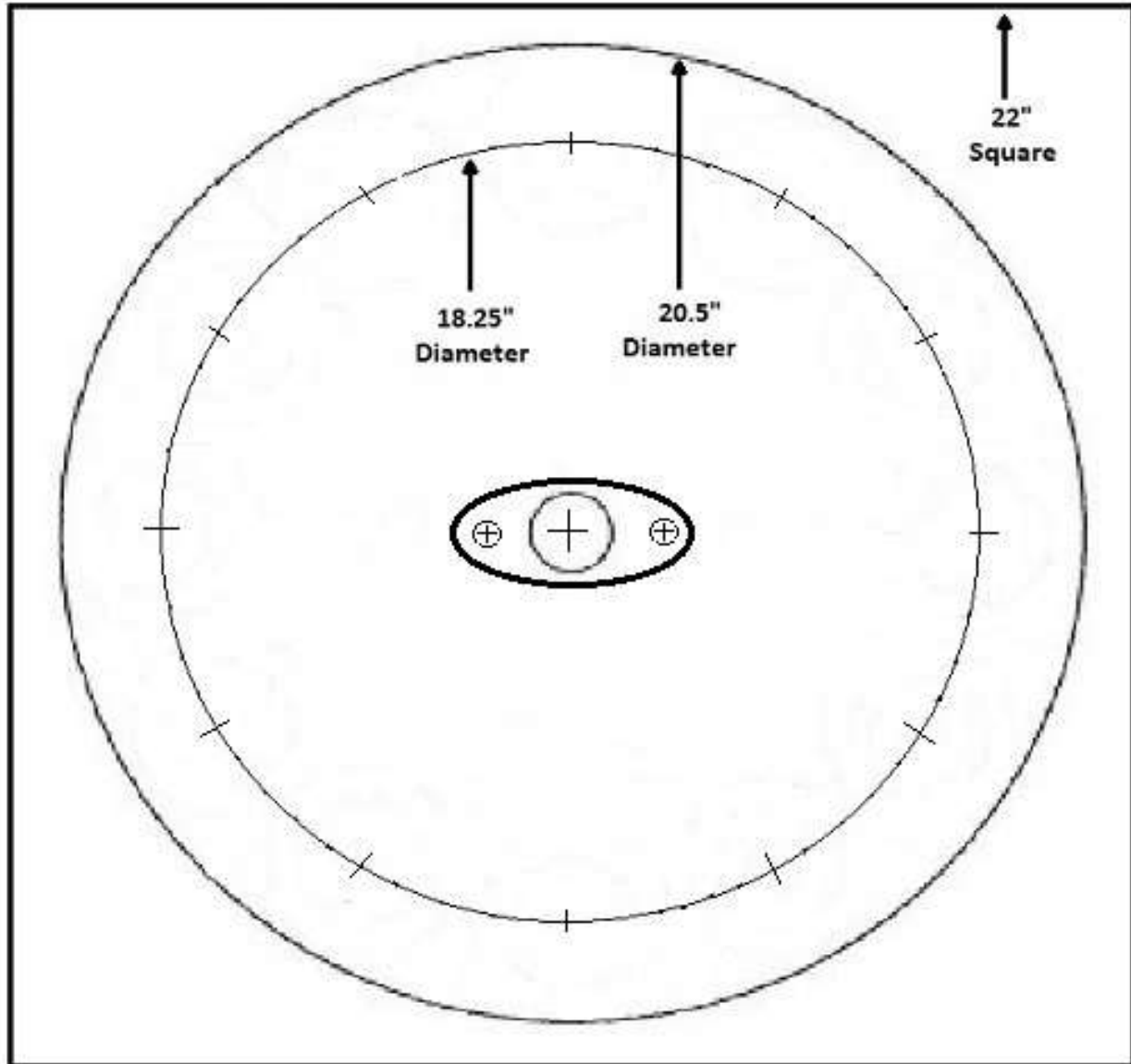

## Step # 3

**Place the second board under the one you just marked and tape them together with duck tape making sure the edges line up then drill the holes for the flange bearing bolts and the clearance hole for the Shaft.**

## Step # 4

**Take the third 22" inch square board find the center and mark a 18.25" inch and a 20.5" inch diameter circle and four holes near the center for the flange that will secure the Rotor to the Shaft and then the 12 marks along the 18.25" diameter circle. Next cut along the 20.5" inch disk line creating the Rotor.**



**Mark 12 evenly spaced lines on this cut edge between the marks on the 18.25" circle. This is where the holes for the Hall Sensor Magnets will be drilled in the edge of the Rotor. This is what it should look like when your done.**

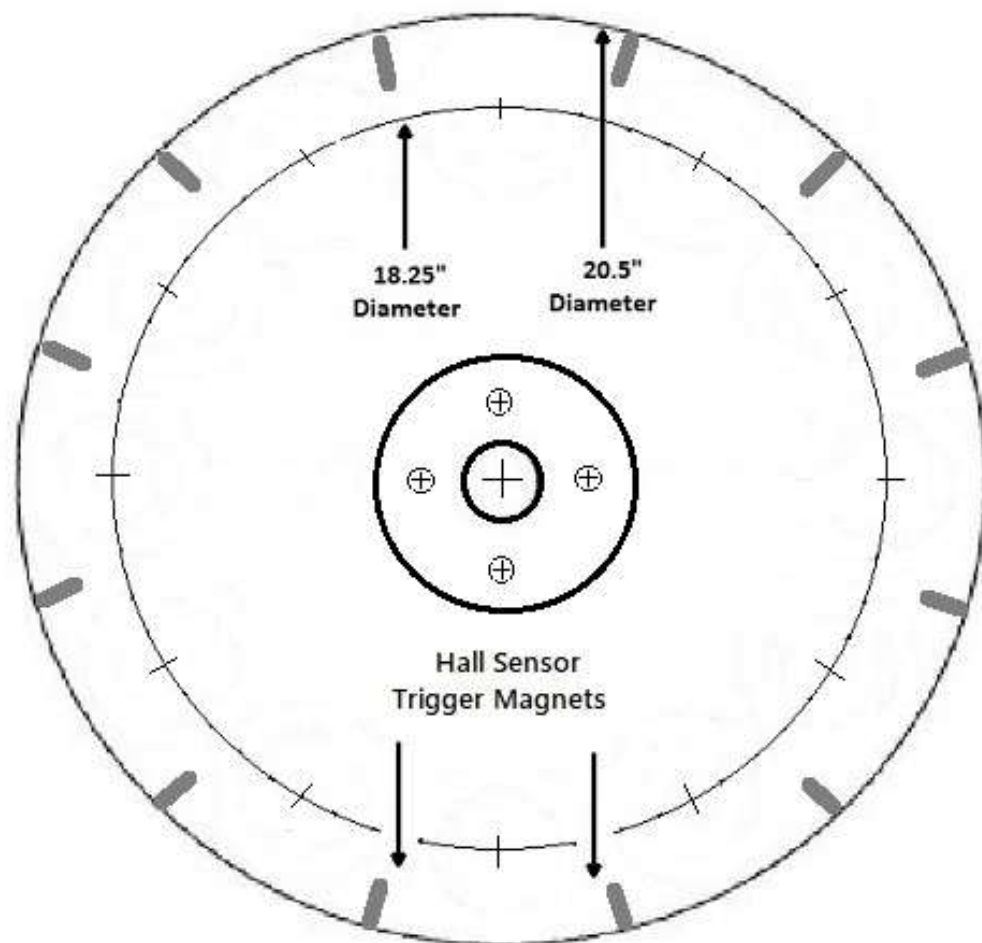

## **Step # 5**

**The Rotor Shaft is going to be the hardest part to make for those of us that don't have Metal Machining Equipment but it can be done.**

**The easy way to do this is to buy a Shaft with a keyway already cut in along with 2 Flange Bearings and 2 Mounting Flanges with the correct size holes for the Shaft.**

**Shaping the end to fit into the Pull Starter is a little tricky. What I did is to take a Q-Tip dip it in Vaseline and coat the Pull Starter Socket a thin film of Vaseline, make sure all surfaces inside the Socket are well coated without any big gobs in there.**

**Then fill the Socket with black RTV. With a flat object scrape the top of the RTV level. You can find a tube of RTV at Home Depot or any car parts store. Let the RTV harden completely it might take 24 to 48 hours.**

**After the curing period is over the RTV plug should pop right out as long as you did a good job coating the Socket with the Vaseline.**

**Now you have a rubber plug that fits into your Pull Starter. Next we're going to use this plug to make a mold we can use to cast a metallic end piece for our Shaft. The easiest way to do this is to mix up some Plaster of Paris, you don't need a lot, half a cup is more than enough. Find a**

**small container like a Jello Pudding cup or the smallest Dixie cup you can get pour about a 1/4” inch of the plaster in the cup and tap the cup on a table to make sure it level and let it harden up.**

**After it's hard place the RTV Plug coated with Vaseline on top of the plaster in the center of your container and slowly pour just enough plaster in to fill up to the top edge of the Plug but “DO NOT COVER THE PLUG” This is very important.**

**After this second pour of plaster has hardened carefully remove the RTV Plug. Now you have a Plaster Mold in which you can cast a Metallic end piece using a product called J B Weld**

**buy it when you get the RTV.**

**J B Weld is great stuff I've used it to fix exhaust systems and cracks in engine blocks and all sorts of metal things.**

**J B Weld is a two part metallic epoxy that needs to be mixed before use. Take equal parts of Part A and Part B mix quickly and thoroughly on a piece of cardboard or a Scrap of wood. Make sure you wear rubber gloves this stuff is toxic but a really fantastic product.**

**When its a uniform color start to press it into the Plaster Mold, work it into the corners and bottom of the Mold before filling the center. Fill the mold right to the top, over filling a little bit is OK. Just make sure to scrape across the top of the Mold so**

**the piece we're making will be flat. You'll have to work quickly once the J B Weld is mixed because it will be rock hard in an hour. You'll only have 5 to 10 minutes to get it into the Mold.**

**After the J B Weld is hard gently tap the Plaster Mold with a hammer until it breaks apart, This is the only way it's coming out of the Mold. Using a Knife or a flat blade screw driver gently scrape any plaster clinging to your new Metallic End Piece.**

**Take the End Piece you made and see if it fits into the Pull Starter Socket. If you did everything right it should fit perfectly. Does it fit? Yes! OK next we attach it to the Rotor Shaft.**

**Take a piece of wood, a short piece of 2x4 will work. Drill a hole just large enough for the Rotor Shaft to fit in. Stick one end of the rotor in the hole, next mix up a tiny bit of J B Weld (about the size of a large Pea) following the directions. Put the small ball of J B Weld on top of the Shaft and put your newly made Metallic End Piece on top of the Ball of J B Weld, Press down the End Piece while keeping it centered on the Shaft and inline with the Shaft, not cocked at an angle. Let it harden up for an hour and you should now have a Rotor Shaft with an end that will fit into the Pull Starter.**

**This is the hardest part of the whole project. If you don't want to do this**

**yourself find a Machine Shop to Mill the end of the Shaft but I know if you can find one to do it the job will be very costly.**

## **Step # 6**

**If you're still with me after the last step lets put the Rotor together. Get the 20.5" inch disk we made earlier it should be marked with a 18.25" diameter circle divided into 12 segments. Drill 12 - 1" inch holes one at each cross mark along the 18.25" inch circle. Next drill the 4 holes for the Mounting Flanges. Next drill the hole for the Rotor Shaft. Finally drill 12 holes around the edge of the disk for the Hall Sensor Trigger Magnets.**



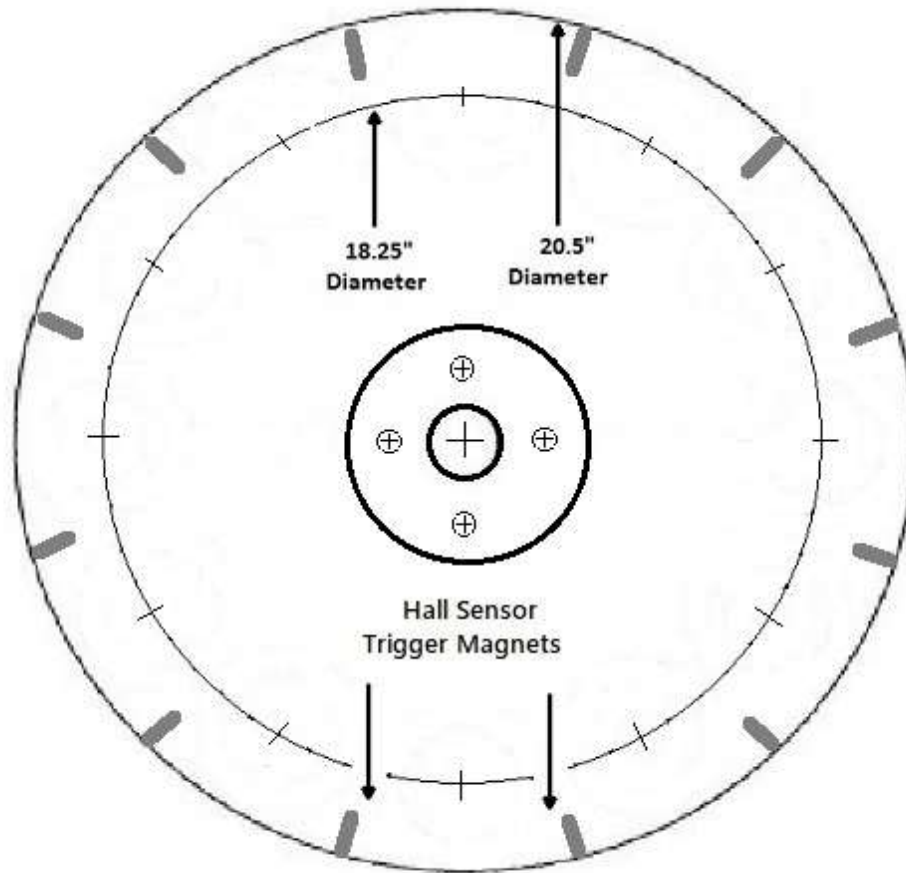

**Using Forstner Bits in a drill press makes perfect flat bottom holes and the holes in the Rotor need to be as straight as possible to ensure the Rotor doesn't wobble while spinning.**

## **Step # 7**

**Next mix up some fast setting epoxy and use it to fasten 12 - 1" inch**

**Magnets into the holes you drilled in the Rotor. Place a couple sheets of plastic wrap on a flat surface and the Rotor disk on top of them so you don't glue the Rotor to the work table. Make sure none of the Magnets are sticking up above the surface of the Rotor.**

## **Step # 8**

**After the epoxy is dry you need to do the same thing with 12 - 1/2" inch long by 1/4" diameter Bar Magnets. Mix up some more epoxy and glue the Bar Magnets into the edge of the Rotor Disk. Wrap a piece of duct tape tightly around the edge of the Rotor Disk so none of the magnets move out of position. You don't want any of**

**them sticking out from the **DISK** edge.**

## **Step # 9**

**Take the Rotor Shaft which should be 9" inches long by 5/8" of an inch diameter and stick in the center hole in the Rotor Disk. Slide both Mounting Flanges on the end of the Shaft one on each side of the Rotor Disk. Line up the keyway's and slide the Key into the Keyway before bolting the Flanges to the Rotor Disk.**

## **Step # 10**

**Winding the coils will take some time but using a cordless drill will make the job less tedious and much faster.**

**Assemble the parts of the coil winder described in Section 1 of the manual. You'll need 2 - 1/4" thick by 2" diameter foam board backing disks, 48 paper thin stiff plastic disks and 24 pieces of plastic tubing cut to the thickness you want to make the coils. How thick you make the coils depends on how strength of your Disk Magnets. Look at the diagram below to see how we determine how long to make the coils.**

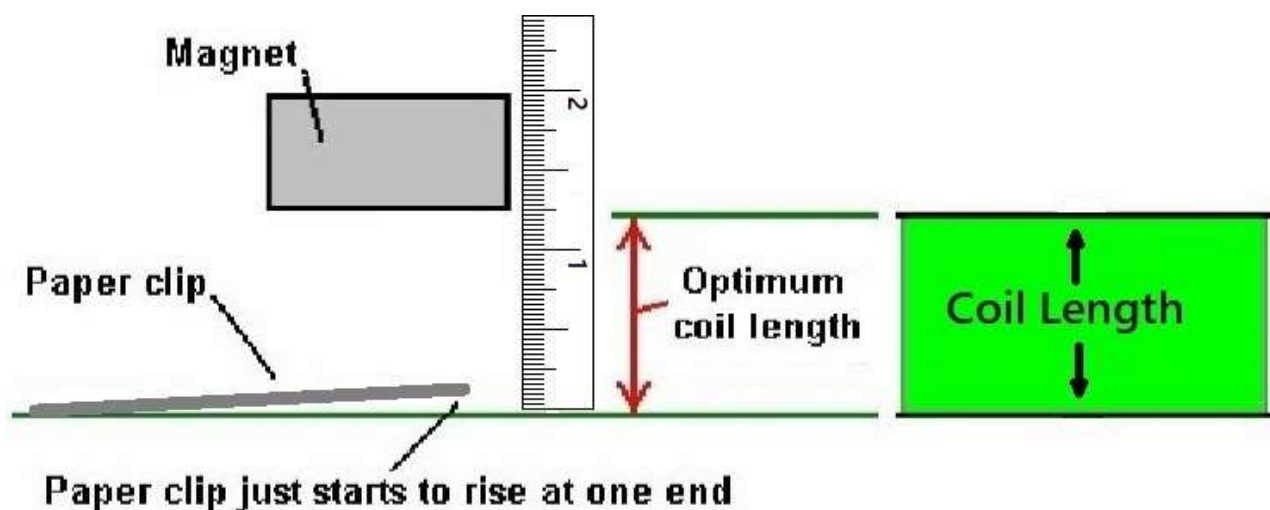

**Hold one of the Rotor Magnets against a wood or plastic ruler over the end of a large paper clip, Slowly lower the Magnet until the paper clip starts to rise off the table. You might have to do this a couple times because the paper clip will jump up to the magnet really fast once it starts to be influenced by the magnetic field.**

**Make a note of where the bottom of the magnet is on the ruler. This how long to cut the tubing for the coil spacers.**

**The Coil Winder is simple to make and easy to use. Assemble it using the picture as a guide.**

**Drill the proper size hole for the threaded insert in a 1 inch long dowel or a block of wood. Next screw the Threaded Insert into the hole, then screw one end of the Threaded rod**

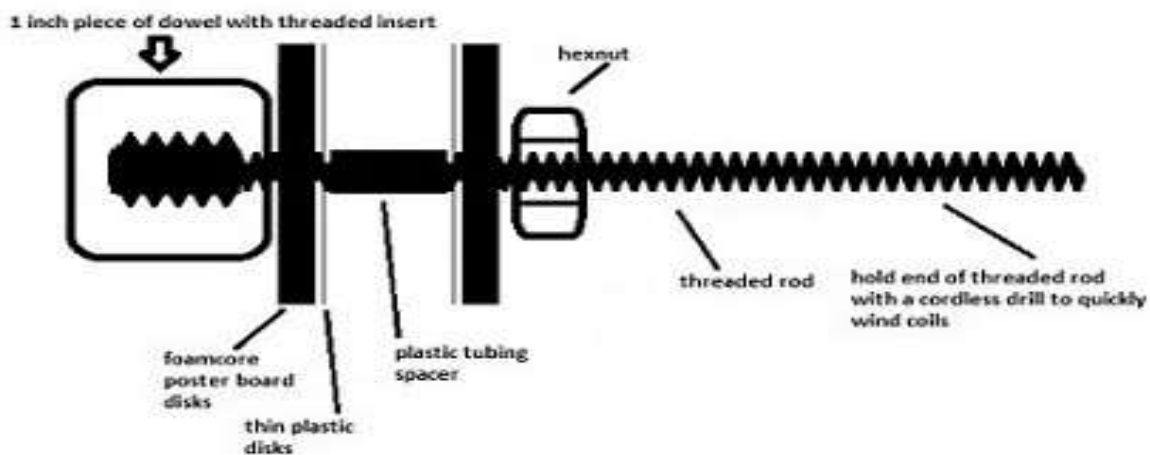

**into the Insert. Slip one Foamcore Disk onto the Rod pushing down to the block of wood followed by one Thin Plastic Disk, one Spacer Tube, another Thin Plastic Disk, another Foamcore Disk and finish by screwing on the Hexnut all the way down to the Coil form. Screw it down**

**snugly but not so tight that it crushes the Coil Form. After winding a coil remove it from the Winder and set it up again for the next Coil.**

## Step # 11

**What wire size should you use?**

Magnets/disk	6	6	9	9	12	12
Number of coils	8	8	11	11	14	14
Rough Wt. of wire	3 LB	6 LB	7 LB	12 LB	13 LB	15 LB
<b>12-V - AWG</b>	#16	#16	#14	#14	#14	#14
Turns per coil	80	140*	80*	110*	95*	110*
<b>24-V - AWG</b>	#19	#16	2@#15	2@#15	2@#14	2@#14
Turns per coil	155	135	50	70	45	52
<b>48-V - AWG)</b>	#22	#19	#15	#15	#14	#14
Turns per coil	310	270	100	140	90	105

**For your first Generator I suggest using one of the setups in the chart.**

**I buy 100 yard rolls and make simple stand to put the roll on. This makes it easy to wind coils.**

**Here's the stand setup for use with the Coil Winder**

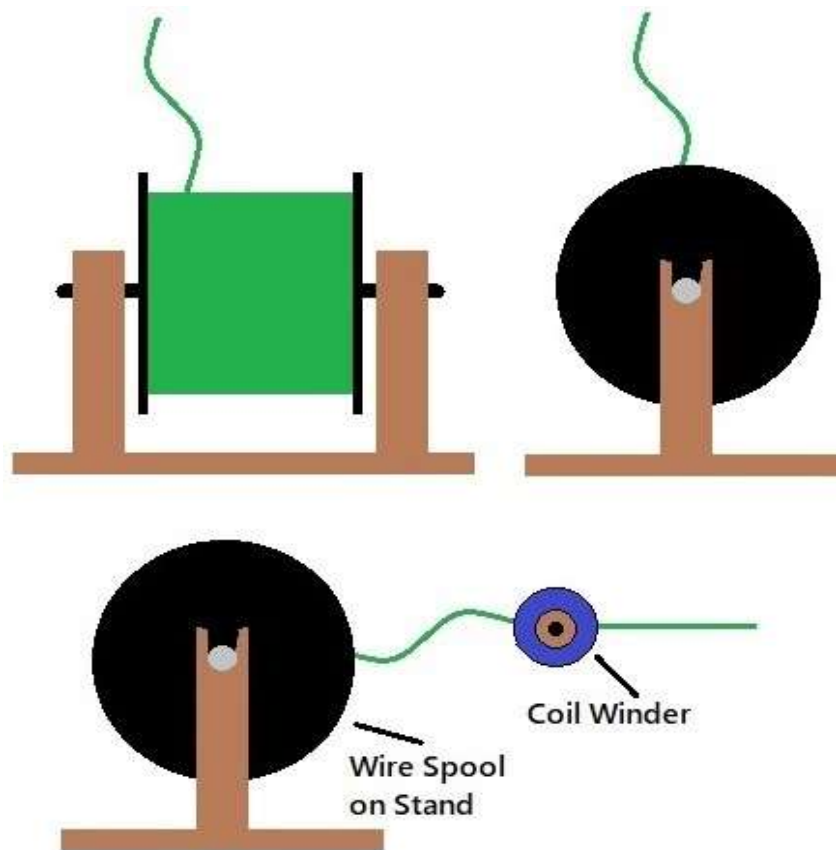

**Take the Coil winder put in a cordless drill like you would with a regular drill bit. Pull about 2 feet of wire off the**



**roll and lay it across the coil winding form leave at least 12” inches sticking out and fold the wire over the side of the form. Tape the wire to the end of the winder to keep it out of the way.**

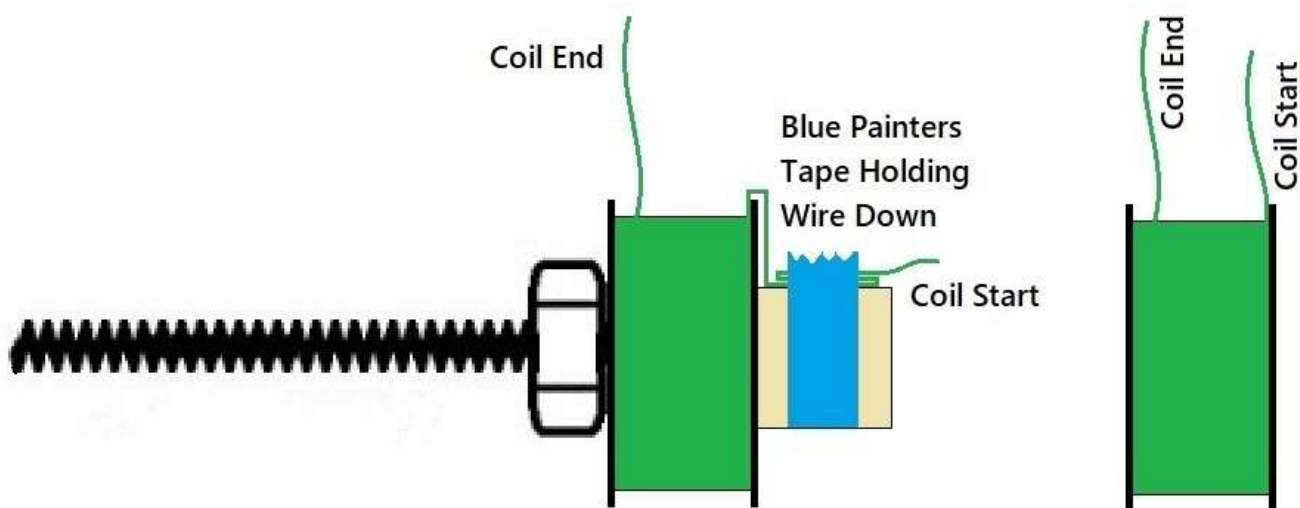

**Hold the wire between the Winder and the Wire Spool with a folded up paper towel, your fingers will thank you for it. Start the drill slowly increase the speed as you get the hang of winding the coils.**

**Fill the coil form evenly and stop about 1/16” inch from the edge of the coil form. Keep tension on the wire and put a few drops of Super Glue around the wound coil. Give it a minute or two to harden before you take the coil off the winder.**

**Reload the winder with another coil form and make the next coil. You'll need 24 coils for a one stage generator. After all the coils are made use super glue to attach the coils to the 22” square plywood panels.**

**Glue 12 coils to each 22” inch square Panel. When your done both panels should look like the picture below.**

**All wires must point to the outer edge  
of the Panel.**

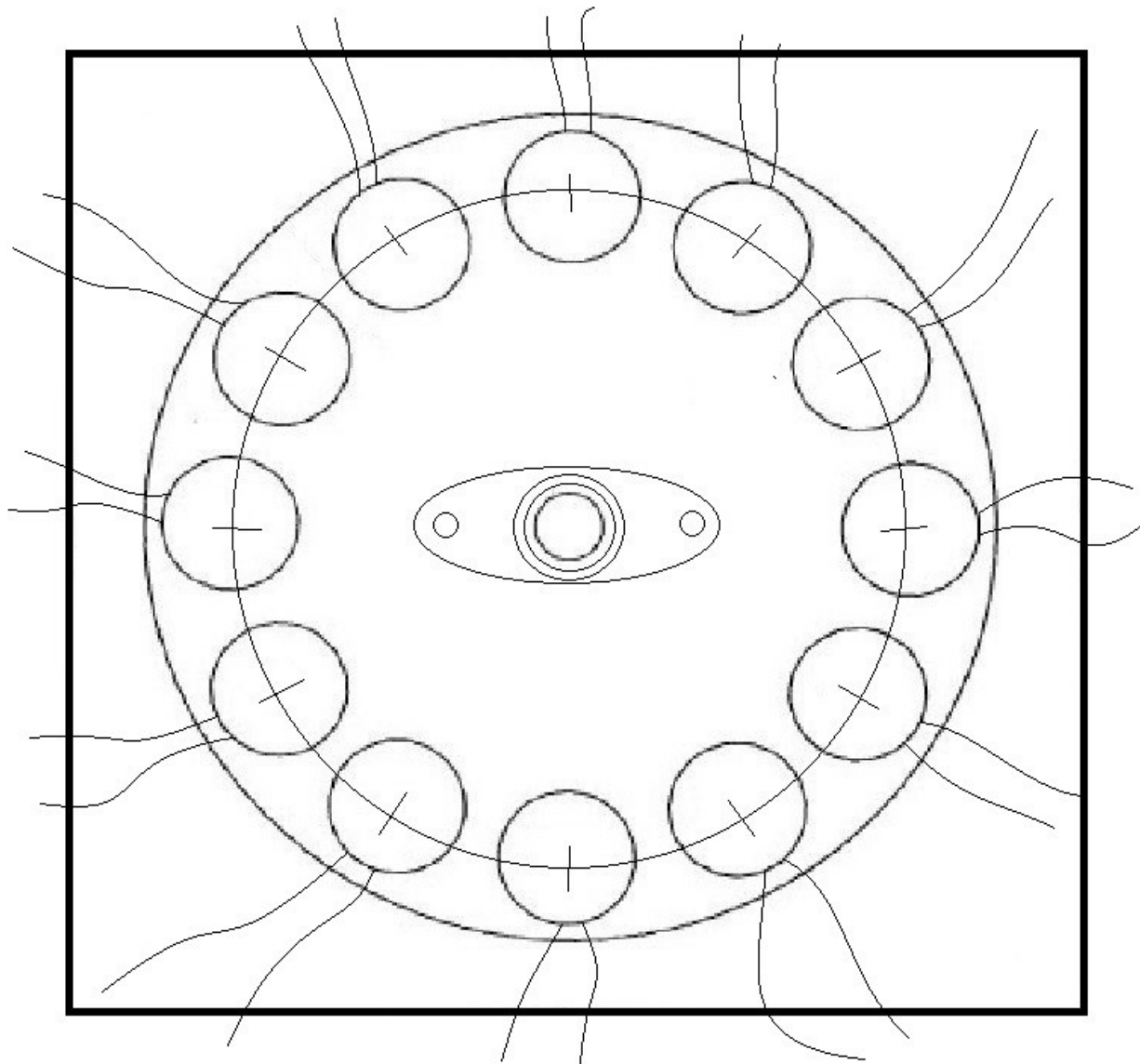

## Step # 12

**Next we're going to put the Rotor Assembly together. It's going to look**

**like this when you're done.**

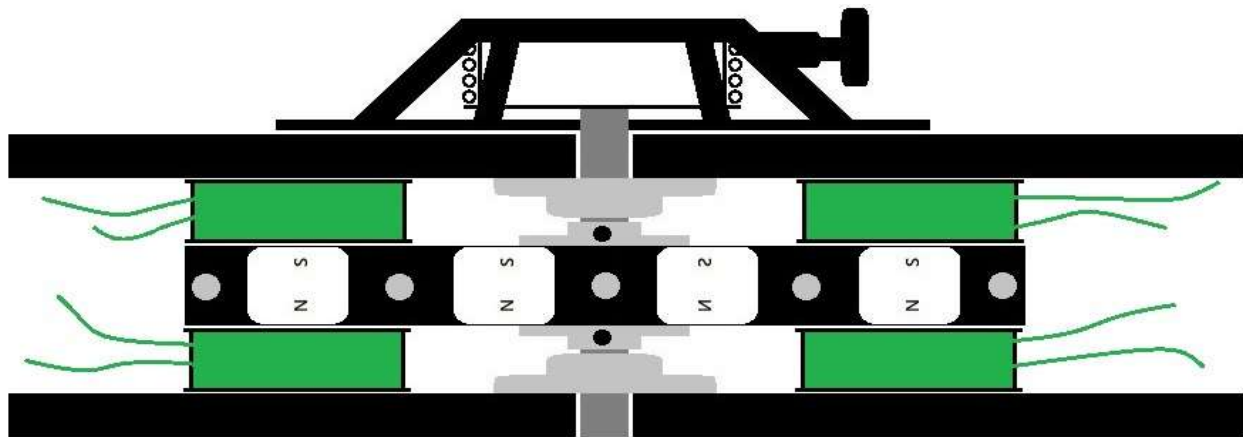

**If you've been making the parts as you go through the manual you should now have the Magnets installed in the Rotor the Coils made and Glued to the square panels and the Rotor Shaft made.**

**Bolt the Mounting Flanges onto the Rotor. Bolt the Flange Bearings onto the Coil Panels, and the Pull Starter to one of the Coil Panels. Now you need four Spacer Sheets no thicker than 1/16" of an inch. These Sheets will be used temporarily to keep the Coils from touching the Rotor. After the spacers are between the Coils and Rotor, Slide the Shaft up through the Flanges and into the Pull Starter Socket. Now you can tighten the set screws on the Flanges to lock the Rotor Shaft to all three Parts.**

**Slide the Spacer Sheets out from between the Panels, look between the Panels to make sure the Coils aren't touching the Rotor. Slowly turn the Rotor while checking for any**

**contact between the it and the Coils.  
Now you can build the box around the  
Rotor Assembly. You'll need some  
1/2" and 1/4" Plywood. This is what it  
should look like before the last side  
is installed.**

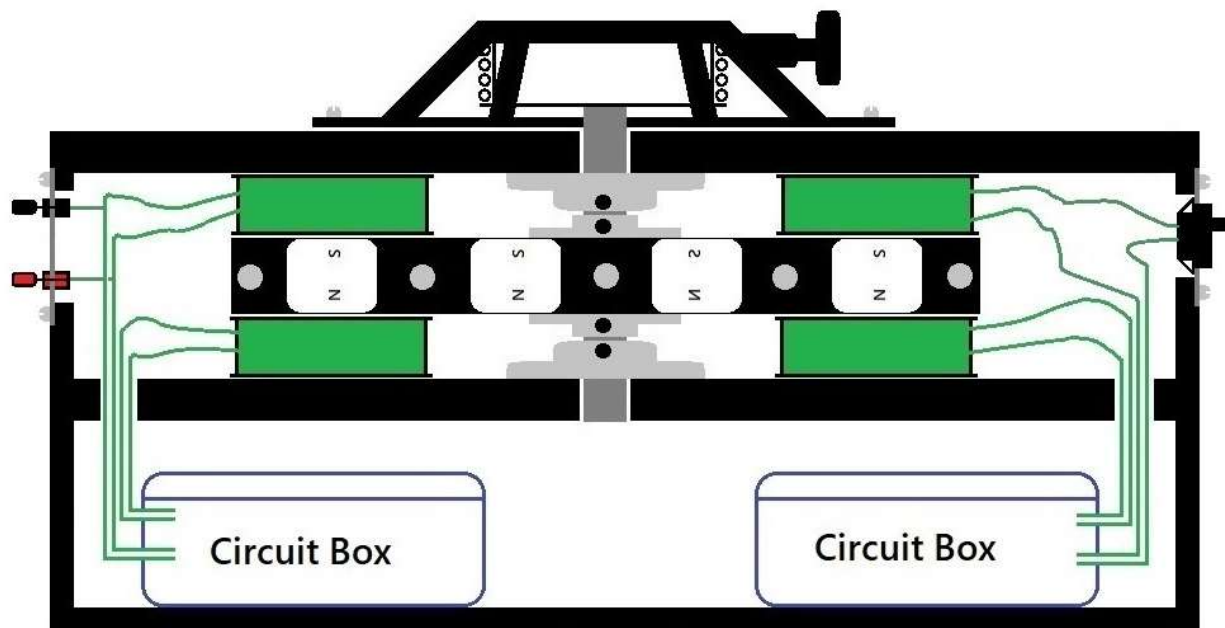

**I can't give you exact measurements  
for the side and bottom of the box.  
You'll have to take measurements off  
the Rotor Assembly. What you're  
going to do is make three sides and a  
bottom to be attached to the Rotor**

**Assembly. Glue and screw the Coil Panels to the sides of the box.**

**Use one and a quarter inch screws.**

**The open space under the Rotor Assembly should be a little bit larger than the Plastic Circuit Boxes you're going to put the control boards into.**

**The fourth side of the box can be made from 1/4" Plywood. Do Not glue this side to the rest of the box, fasten it to the rest to box only with screws.**

**On this 1/4" Cover Panel you're going to mount the power cut off switch, output terminals and the Plastic boxes. Make sure to put these parts where they won't hit the sides of the box or the Rotor Assembly. Make sure to leave all the wires long enough so you can unscrew the cover and move it away to work inside if you need to.**

# Section 5

## Wire Connections

**The wiring schematic shows how the all of the coils and other components are connected together. When you start wiring everything up remember that the wires will need to be long enough to reach to the boxes in the space under the Rotor Assembly and to the switch and output terminals mounted on the box cover.**

**You'll be able to find someone to do all this for you at a local Maker Space. If you don't have one close, try a Technical Collage or a local Computer Geek.**



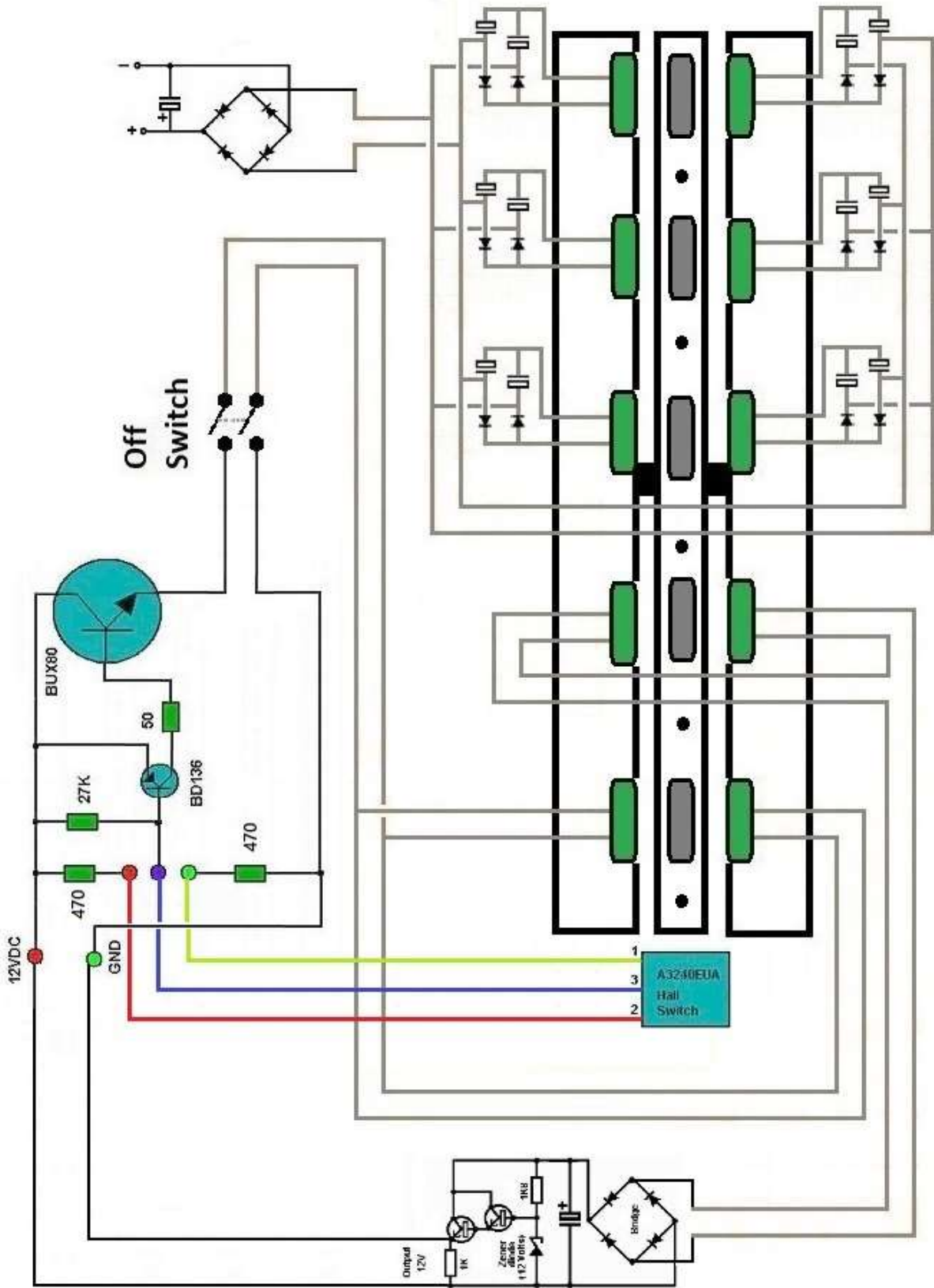

**The power created needs to be fed into an Adjustable Regulated Power Supply and be adjusted to put out 12 volts DC. This must be done while the generator is running. This adjustment only needs to be done once when the assembly of the Generator is finished. Hooking up a Power Inverter to the output terminals will produce 120 volts AC.**

# Section 5

## Making it Bigger

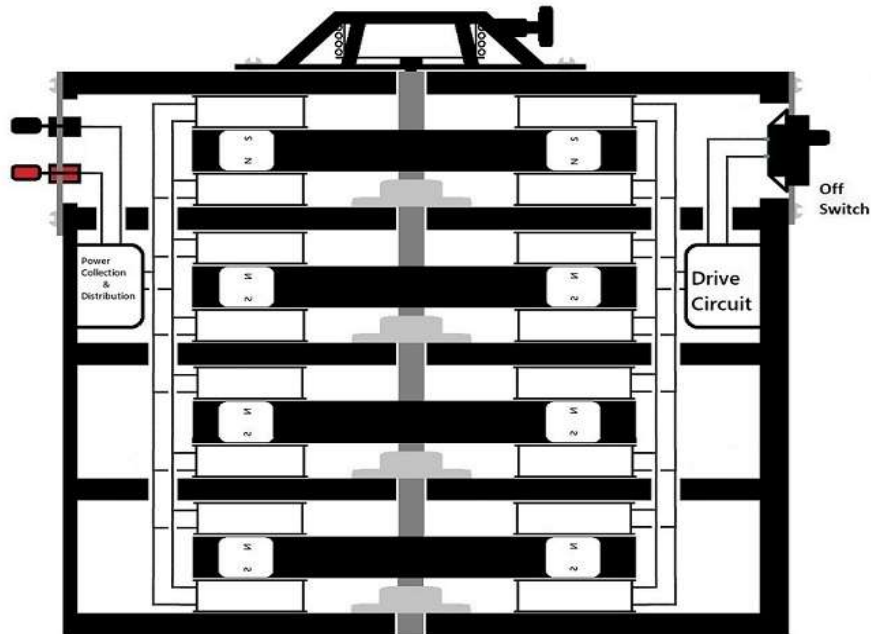

**Creating a larger device can be as simple as making a longer Rotor Shaft and additional Rotor and Coil Panels and installing them in a larger enclosure.**

**Or you could make all components bigger. Your only limited by the size of your bank account.**

**Big magnets can be very expensive, especially if you need 4 or 5 dozen instead of just 1 dozen. Copper wire is also expensive in larger wire gauges.**

**A larger device means more power produced and even the smallest Generator will create a lethal power level.**

**Now that you know how to build a Fuel less Free Energy Generator with three or four smaller units you could power an Off-Grid Home, Boat or RV**

# Section 6

## Builder's Resources

**Here's a list of suppliers for everything you'll need. As of the date of publication all Sources have been verified.**

<https://www.homedepot.com>

<https://www.lowes.com>

<https://www.acehardware.com>

---

<https://allmagnetics.com/surplus.htm>

<https://appliedmagnets.com>

<https://www.kjmagnetics.com>

---

<https://www.mcmaster.com/>

<https://www.grainger.com>

<https://bulkwire.com/magnet-wire>

---

**<https://bearingsdirect.com/>**

**<https://www.thebigbearingstore.com/>**

---

**<https://www.icecomponents.com/>**

**<https://www.digikey.com/>**

**<http://www.surplus-electronics-sales.com/>**

**<https://www.electronicssurplus.com/>**

**<https://www.galco.com>**

---

**<https://www.makerspaces.com/what-is-a-makerspace/>**

**<https://picclick.com/1800W-40A-DC-DC-Boost-Converter-Step-Up-Power-183867065963.html>**

# Notes

## **NEED HELP BUILDING A GENERATOR ?**

**James Edward Freach the author, writing under the Pen-Name  
J.G.Homesworth is available as an Alternative Energy Consultant.**

**To inquire about Fees, Terms and Availability or  
for Manufacturing Partnership Inquiry**

**Contact:**

**James Edward Freach  
322 Mall Blvd, Suite 175  
Monroeville, Pa, 15146**

**[info@jghomesworth.com](mailto:info@jghomesworth.com)**

**\$79.95**

## **Build Your Own Free Energy Generator**

**Copyright © 2019**

**ISBN: 978-0-578-62721-2**

**There's nothing magical about Free Energy, and by Free Energy I mean something that produces usable energy without the need for Expensive Fuel which you have to buy.**

**Free Energy Devices have been around for a very very long time. If you have ever stood next to a Water Mill you know it's a large, powerful energy producing device that runs day and night without stopping, It pulls in free energy from the surrounding environment and does a tremendous amount of work without having to pay for the power it uses to run.**

**It cost quite a lot to build the Mill but after that it operates for free year after year. Most Free Energy Devices are just like that, as it costs a lot to build one but after that it runs for FREE!!!**

**This book is for people that have had little if any exposure to Free Energy but would like to learn more. The device described in the book is explained in simple terms and with diagrams that clearly show how the device is built and operates.**

